

7CH DARLINGTON SINK DRIVER

The TD62001P/AP/F/AF Series are high-voltage, high-current darlington drivers comprised of seven NPN darlington pairs.

All units feature integral clamp diodes for switching inductive loads.

Applications include relay, hammer, lamp and display (LED) drivers.

FEATURES

- Output current (single output) 500mA MAX.
- High sustaining voltage output
35V MIN. (TD62001P/F Series)
50V MIN. (TD62001AP/AF Series)
- Output clamp diodes
- Inputs compatible with various types of logic
- Package Type-P, AP : DIP-16pin
- Package Type-F, AF : SOP-16pin

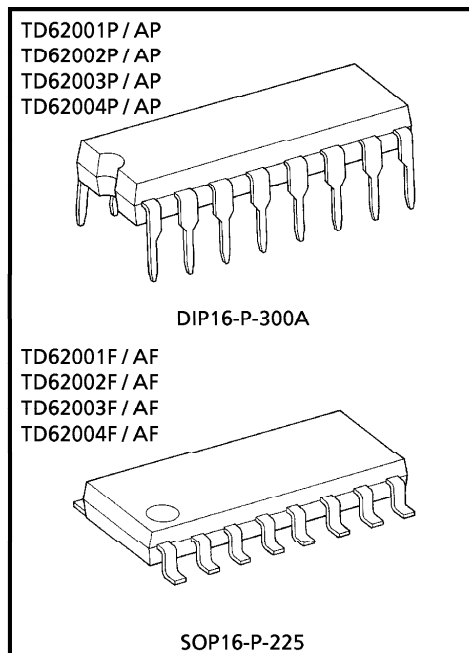

Weight DIP16-P-300A : 1.11g (Typ.)
SOP16-P-225 : 0.16g (Typ.)

TYPE	INPUT BASE RESISTOR	DESIGNATION
TD62001P/AP/F/AF	External	General Purpose
TD62002P/AP/F/AF	10.5-k Ω + 7V Zenner diode	14~25V PMOS
TD62003P/AP/F/AF	2.7k Ω	TTL, 5V CMOS
TD62004P/AP/F/AF	10.5k Ω	6~15V PMOS, CMOS

PIN CONNECTION (TOP VIEW)

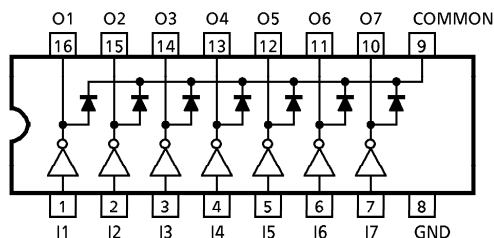

© The information contained herein is presented only as a guide for the applications of our products. No responsibility is assumed by TOSHIBA CORPORATION for any infringements of intellectual property or other rights of the third parties which may result from its use. No license is granted by implication of otherwise under any intellectual property or other rights of TOSHIBA CORPORATION or others.

© These TOSHIBA products are intended for use in general commercial applications (office equipment, communication equipment, measuring equipment, domestic appliances, etc.). please make sure that you consult with us before you use these TOSHIBA products in equipment which requires extraordinarily high quality and/or reliability, and in equipment which may involve life threatening or critical application, including but not limited to such uses as atomic energy control, airplane or spaceship instrumentation, traffic signals, medical instrumentation, combustion control, all types of safety devices, etc. TOSHIBA cannot accept and hereby disclaims liability for any damage which may occur in case the TOSHIBA products are used in such equipment or applications without prior consultation with TOSHIBA.

SCHEMATICS (EACH DRIVER)

TD62001P / AP / F / AF

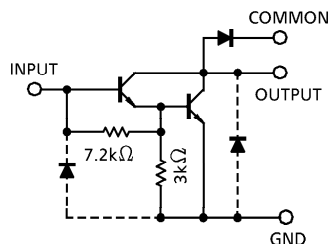

TD62002P / AP / F / AF

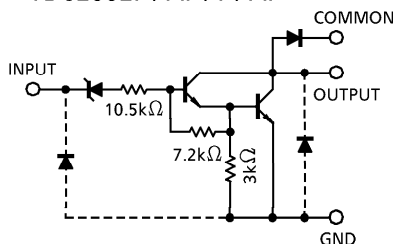

TD62003P / AP / F / AF

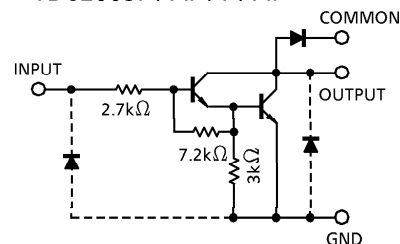

TD62004P / AP / F / AF

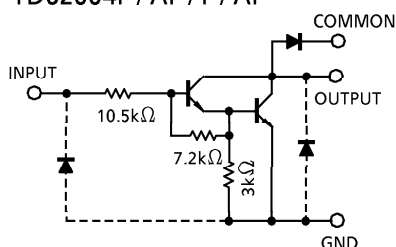

(Note) The input and output parasitic diodes cannot be used as clamp diodes.

MAXIMUM RATINGS (Ta = 25°C)

CHARACTERISTIC		SYMBOL	RATING	UNIT
Output Sustaining Voltage	P, F	V _{CE (SUS)}	- 0.5~35	V
	AP, AF		- 0.5~50	
Output Current		I _{OUT}	500	mA / ch
Input Voltage		V _{IN} (Note 1)	- 0.5~30	V
Input Current		I _{IN} (Note 2)	25	mA
Clamp Diode Reverse Voltage	P, F	V _R	35	V
	AP, AF		50	
Clamp Diode Forward Current		I _F	500	mA
Power Dissipation	P	P _D	1.0	W
	AP		1.47	
	F, AF		0.54 / 0.69 (Note 3)	
Operating Temperature	P	T _{opr}	- 30~75	°C
	AP, F, AF		- 40~85	
Storage Temperature		T _{stg}	- 55~150	°C

(Note 1) Except TD62001P / AP / F / AF

(Note 2) Only TD62001P / AP / F / AF

(Note 3) On glass epoxy PCB (30 × 30 × 1.6mm Cu 50%)

RECOMMENDED OPERATING CONDITIONS ($T_a = -40 \sim 85^\circ\text{C}$ and $T_a = -30 \sim 75^\circ\text{C}$ for only Type-P)

CHARACTERISTIC		SYMBOL	CONDITION	MIN.	TYP.	MAX.	UNIT	
Output Sustaining Voltage	P, F	$V_{CE(SUS)}$		0	—	35	V	
	AP, AF			0	—	50		
Output Current	AP	I_{OUT}	$T_{pw} = 25\text{ms}$ 7 Circuits $T_a = 85^\circ\text{C}$ $T_j = 120^\circ\text{C}$	Duty = 10%	0	—	370	mA / ch
				Duty = 50%	0	—	130	
	P			Duty = 10%	0	—	295	
				Duty = 50%	0	—	95	
	F, AF			Duty = 10%	0	—	233	
				Duty = 50%	0	—	70	
Input Voltage	Except TD62001P / AP / F / AF	V_{IN}		0	—	24	V	
Input Voltage (Output On)	TD62002	$V_{IN(ON)}$	$I_{OUT} = 400\text{mA}$ $h_{FE} = 800$	14.5	—	24	V	
	TD62003			2.8	—	24		
	TD62004			6.2	—	24		
Input Voltage (Output Off)	TD62001	$V_{IN(OFF)}$		0	—	0.6	V	
	TD62002			0	—	7.4		
	TD62003			0	—	0.7		
	TD62004			0	—	1.0		
Input Current	Only TD62001	I_{IN}		0	—	10	mA	
Clamp Diode Reverse Voltage	P, F	V_R		—	—	35	V	
	AP, AF			—	—	50		
Clamp Diode Forward Current		I_F		—	—	350	mA	
Power Dissipation	P	P_D	$T_a = 85^\circ\text{C}$ (Note) $T_a = 85^\circ\text{C}$	—	—	0.6	W	
	AP			—	—	0.76		
	AF, F			—	—	0.36		

(Note) On glass epoxy PCB (30×30×1.6mm Cu 50%)

ELECTRICAL CHARACTERISTICS (Ta = 25°C unless otherwise noted)

CHARACTERISTIC		SYMBOL	TEST CIRCUIT	TEST CONDITION	MIN.	TYP.	MAX.	UNIT	
Output Leakage Current	AP, AF	ICEX	1	VCE = 50V, Ta = 25°C	—	—	50	μA	
				VCE = 50V, Ta = 85°C	—	—	100		
	F			VCE = 35V, Ta = 25°C	—	—	50		
				VCE = 35V, Ta = 85°C	—	—	100		
	P			VCE = 35V, Ta = 25°C	—	—	50		
				VCE = 35V, Ta = 75°C	—	—	100		
Collector-Emitter Saturation Voltage		VCE (sat)	2	IOUT = 350mA, IIN = 500μA	—	1.3	1.6	V	
				IOUT = 200mA, IIN = 350μA	—	1.1	1.3		
				IOUT = 100mA, IIN = 250μA	—	0.9	1.1		
DC Current Transfer Ratio		hFE	2	VCE = 2V, IOUT = 350mA	1000	—	—		
Input Current (Output On)	TD62002	IIN (ON)	3	VIN = 20V, IOUT = 350mA	—	1.1	1.7	mA	
	TD62003			VIN = 2.4V, IOUT = 350mA	—	0.4	0.7		
	TD62004			VIN = 9.5V, IOUT = 350mA	—	0.8	1.2		
Input Current (Output Off)	P	IIN (OFF)	4	IOUT = 500μA, Ta = 75°C	50	65	—	μA	
	AP, F, AF			IOUT = 500μA, Ta = 85°C	50	65	—		
Input Voltage (Output On)	TD62002	VIN (ON)	5	VCE = 2V hFE = 800	IOUT = 350mA	—	—	13.7	V
					IOUT = 200mA	—	—	11.4	
	TD62003				IOUT = 350mA	—	—	2.6	
					IOUT = 200mA	—	—	2.0	
	TD62004				IOUT = 350mA	—	—	4.7	
					IOUT = 200mA	—	—	4.4	
Clamp Diode Reverse Current	AP, AF	IR	6	VR = 50V, Ta = 25°C	—	—	50	μA	
				VR = 50V, Ta = 85°C	—	—	100		
	F			VR = 35V, Ta = 25°C	—	—	50		
				VR = 35V, Ta = 85°C	—	—	100		
	P			VR = 35V, Ta = 25°C	—	—	50		
				VR = 35V, Ta = 75°C	—	—	100		
Clamp Diode Forward Voltage		VF	7	IF = 350mA	—	—	2.0	V	
Input Capacitance		CIN	—		—	15	—	pF	
Turn-On Delay	P, F	tON	8	VOUT = 35V, RL = 87.5Ω CL = 15pF	—	0.1	—	μs	
	AP, AF			VOUT = 50V, RL = 125Ω CL = 15pF	—	0.1	—		
Turn-Off Delay	P, F	tOFF	8	VOUT = 35V, RL = 87.5Ω CL = 15pF	—	0.2	—		
	AP, AF			VOUT = 50V, RL = 125Ω CL = 15pF	—	0.2	—		

TEST CIRCUIT

1. I_{CEX}

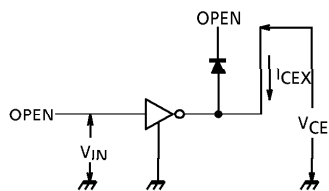

2. $V_{CE(sat)}$, h_{FE}

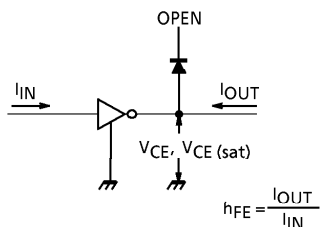

3. $I_{IN(ON)}$

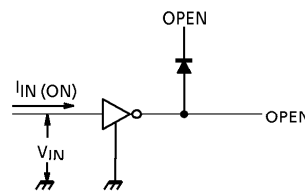

4. $I_{IN(OFF)}$

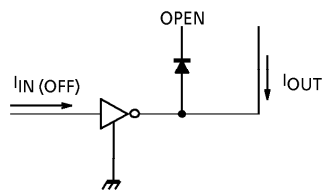

5. $V_{IN(ON)}$

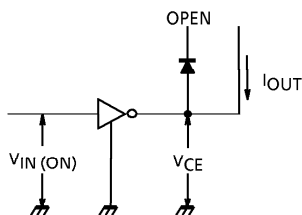

6. I_R

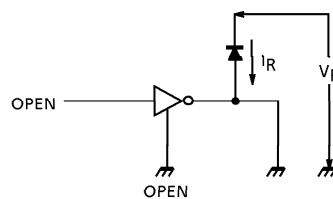

7. V_F

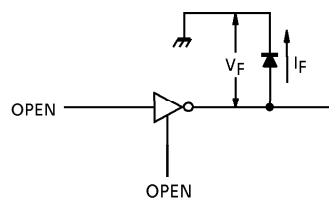

8. t_{ON} , t_{OFF}

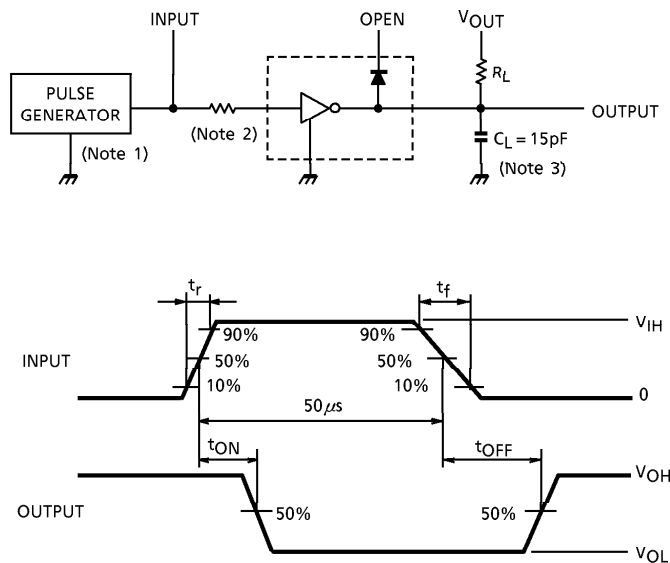

- (Note 1) Pulse width $50\mu s$, duty cycle 10%
Output impedance 50Ω , $t_r \leq 5ns$, $t_f \leq 10ns$
(Note 2) See below

INPUT CONDITION

TYPE NUMBER	R1	V_{IH}
TD62001P/AP/F/AF	$2.7k\Omega$	3V
TD62002P/AP/F/AF	0	13V
TD62003P/AP/F/AF	0	3V
TD62004P/AP/F/AF	0	8V

- (Note 3) C_L includes probe and jig capacitance.

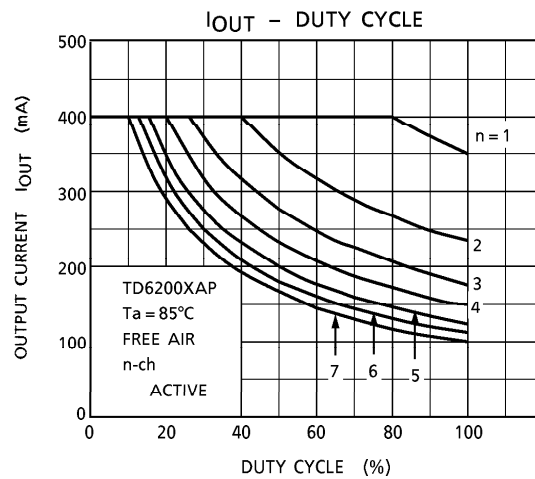
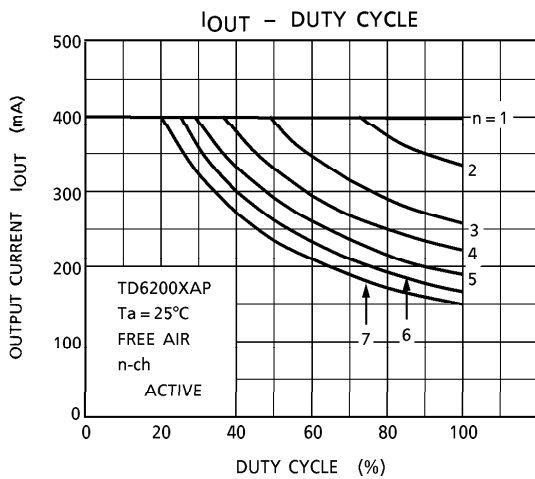
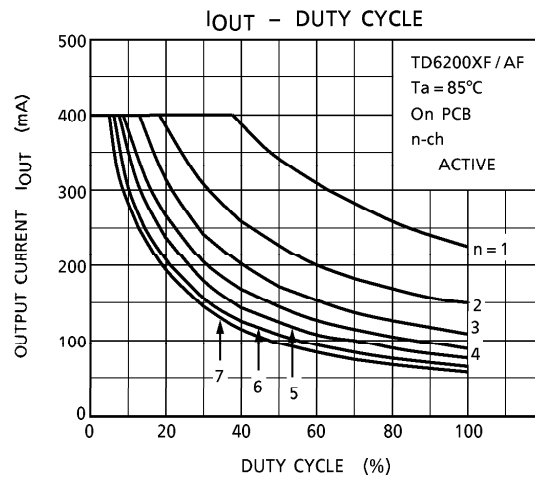
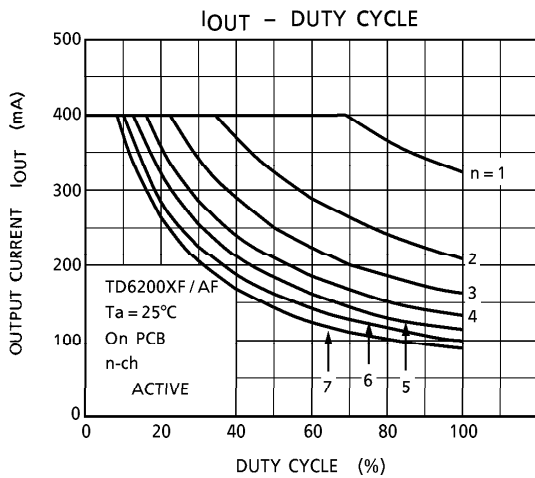
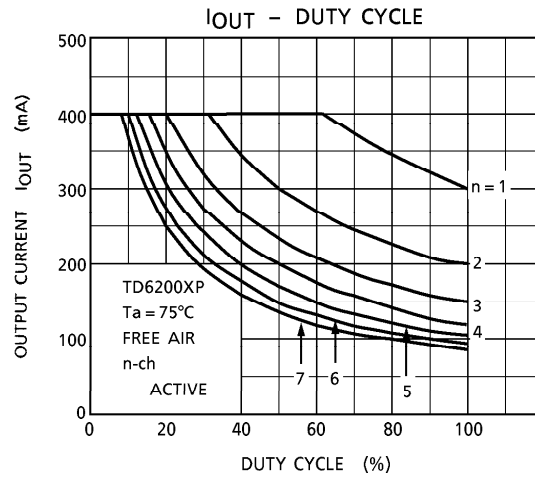
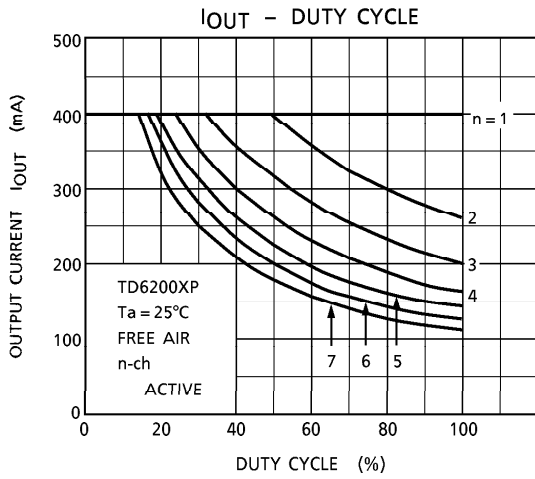

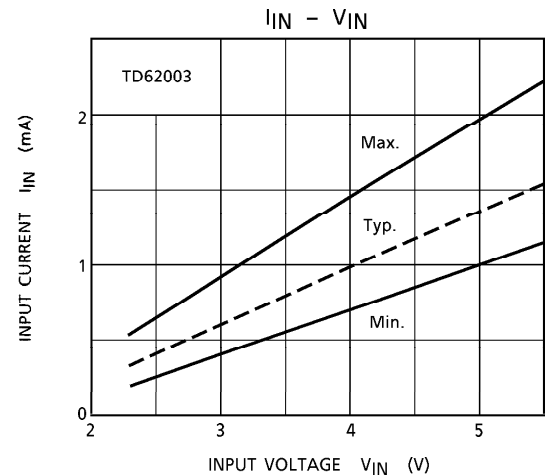
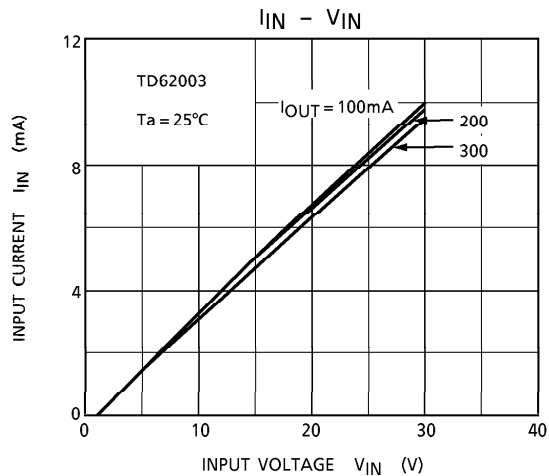
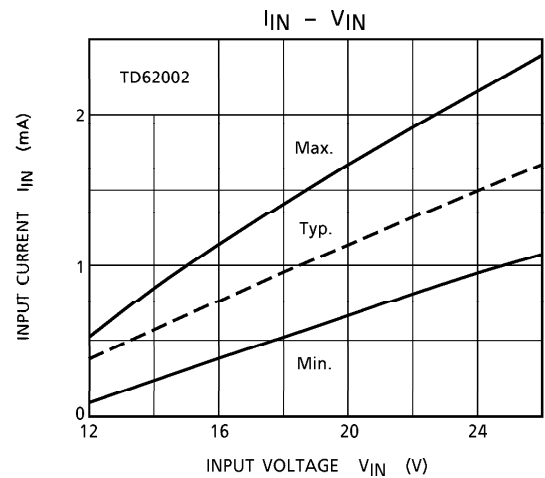
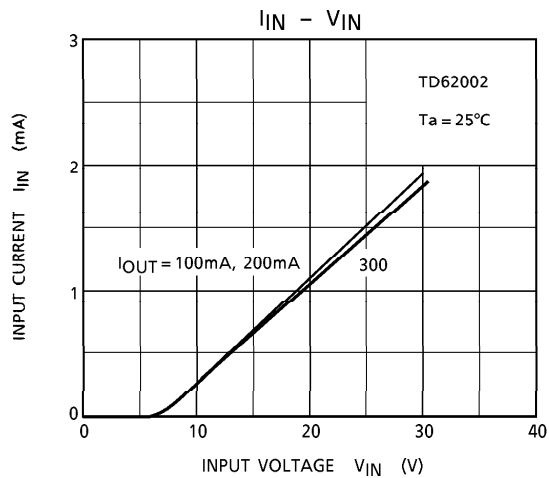
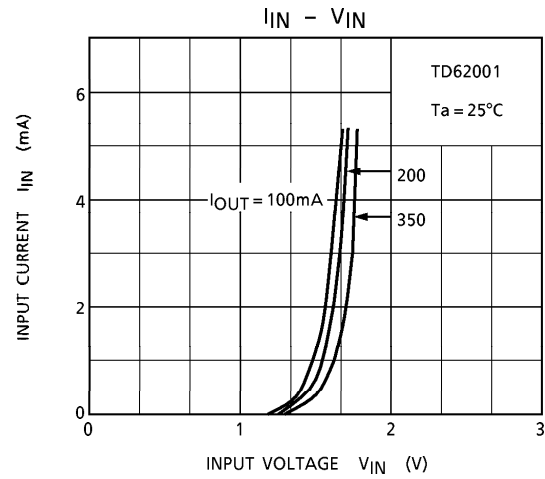
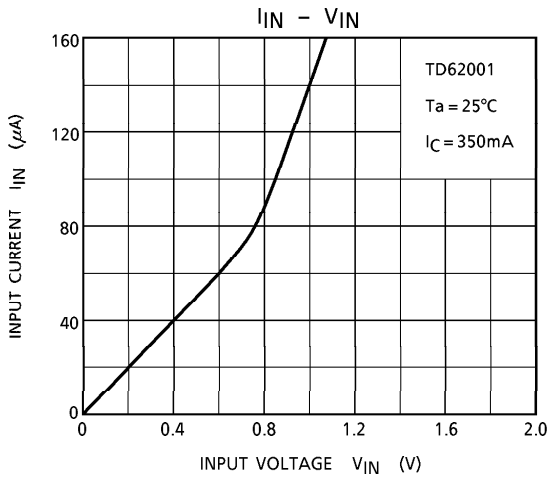

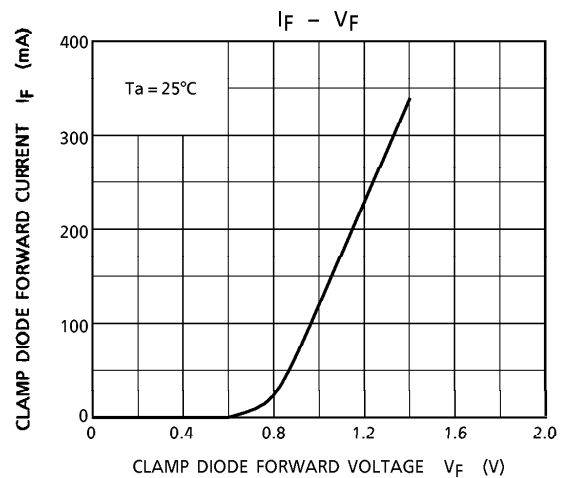
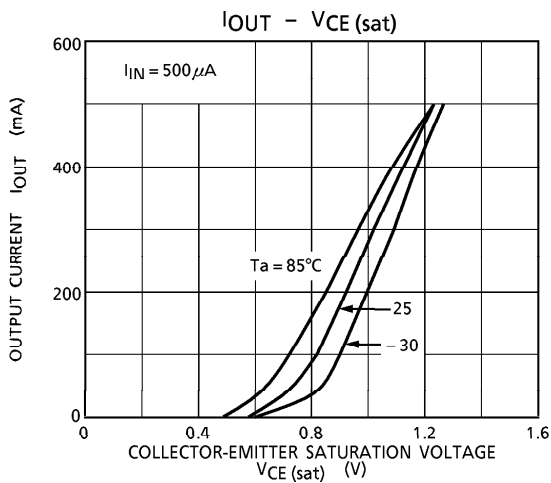
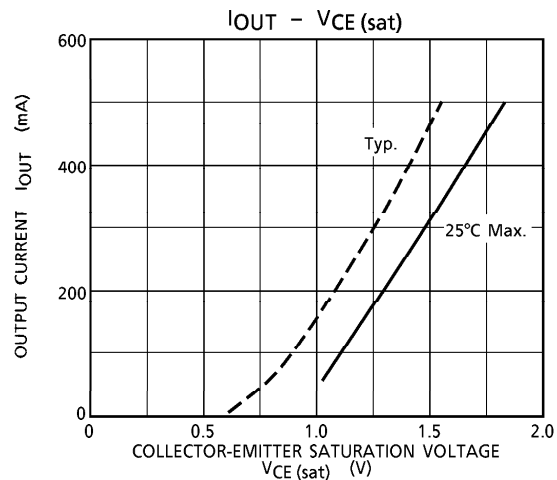
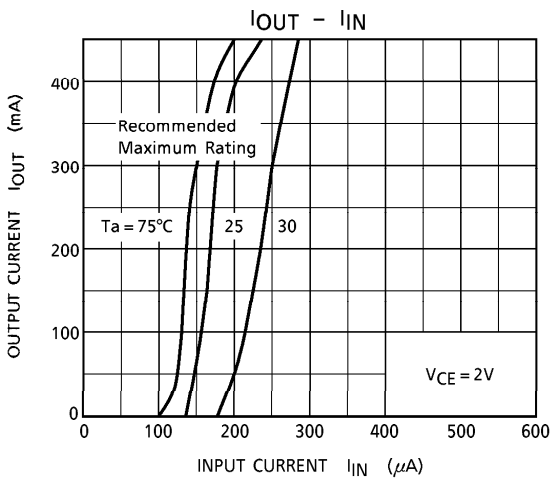
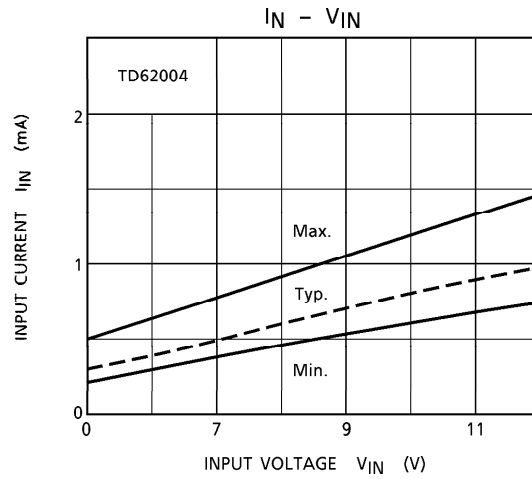
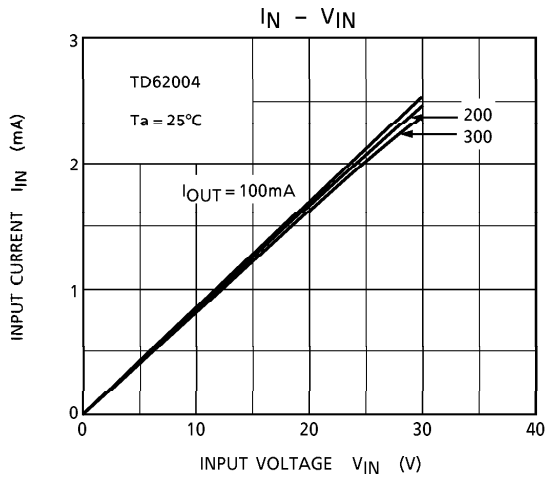

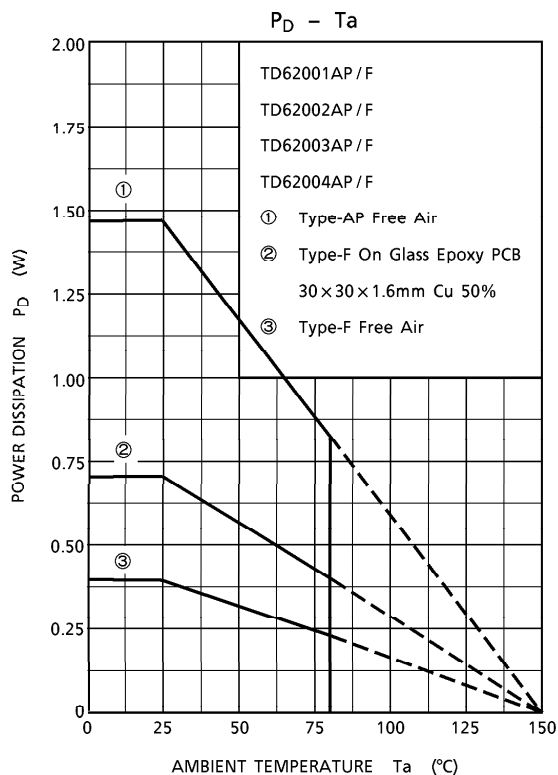
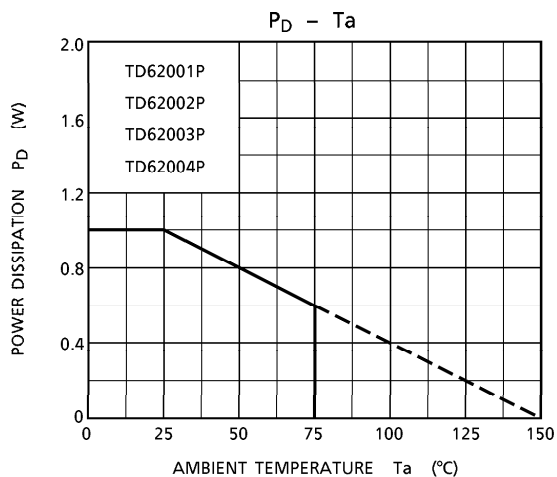

OUTLINE DRAWING
DIP16-P-300A

Unit : mm

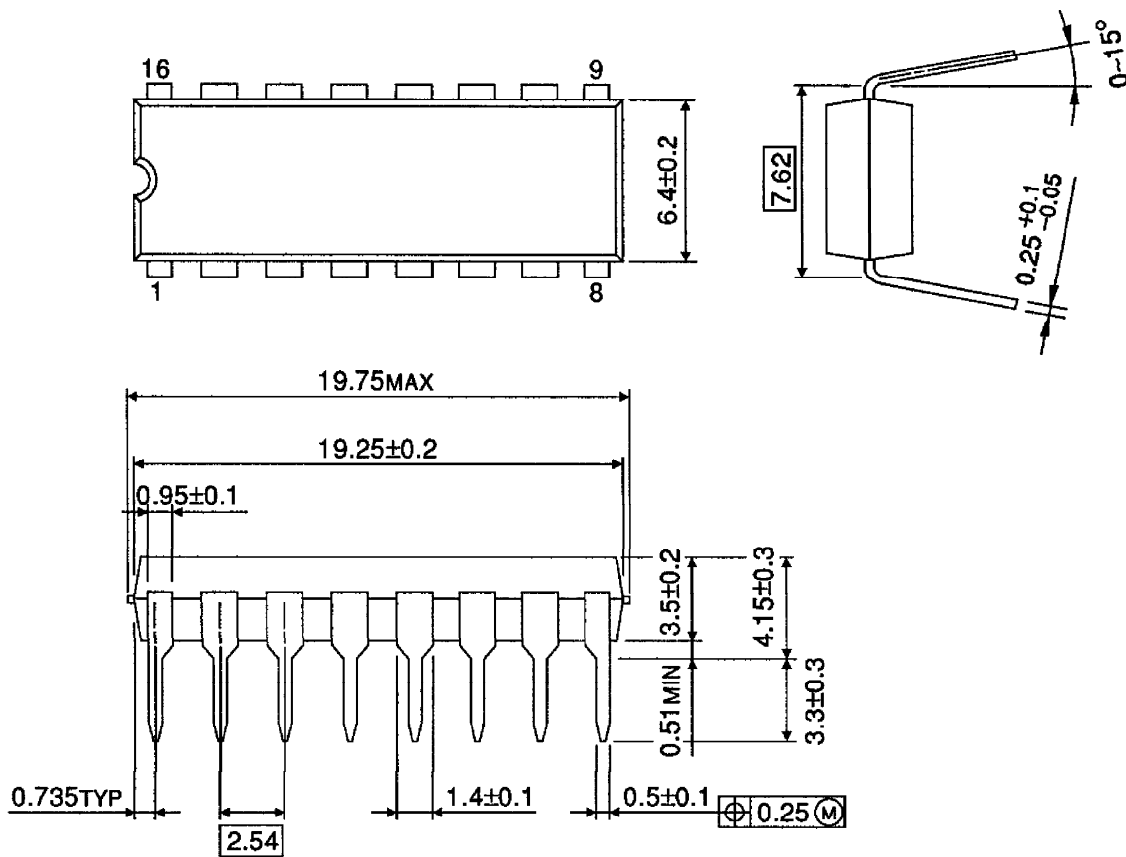

Weight : 1.11g (Typ.)

OUTLINE DRAWING
SOP16-P-225

Unit : mm

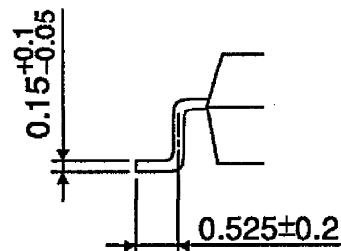
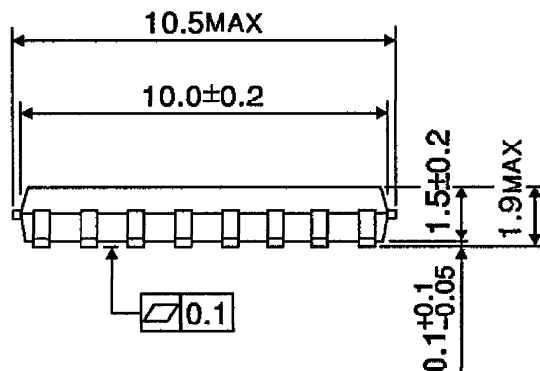
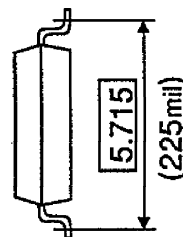
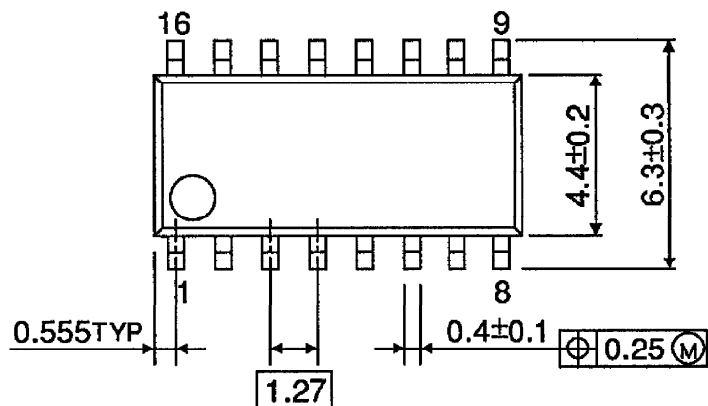

Weight : 0.16g (Typ.)